



**Arboricultural Impact Assessment
and
Arboricultural Method Statement
for
Pontyfelin Lane,
New Inn,
Pontypool**

*Inspected by:-
Julian Wilkes BSc.For, MSc.Land Man, MIC.For, TechArb
Treescene Ltd
The Walled Garden
Old Coedarhydyglyn
St Nicholas
Cardiff
CF5 6SG
Tel No. 029 20599300*

20th February, 2023

**Registered Office: Treescene Limited
The Walled Garden, Old Coedarhydyglyn, St. Nicholas, Cardiff CF5 6SG
Tel. 029 205 99300 Email. trees@treescene.co.uk**



**Arboricultural Impact Assessment
for
Pontyfelin Lane,
New Inn,
Pontypool**

*Inspected by:-
Julian Wilkes BSc.For, MSc.Land Man, MIC.For, TechArb
Treescene Ltd
The Walled Garden
Old Coedarhydyglyn
St Nicholas
Cardiff
CF5 6SG
Tel No. 029 20599300*

20th February, 2023

**Registered Office: Treescene Limited
The Walled Garden, Old Coedarhydyglyn, St. Nicholas, Cardiff CF5 6SG
Tel. 029 205 99300 Email. trees@treescene.co.uk**

1. BRIEF

I have been instructed by Mr. Owain Morgan of Arup to prepare an Arboricultural Impact Assessment (AIA) in relation to a proposed development at Pontyfelin Lane, New Inn, Pontypool.

2. TREE SURVEY AND PLAN

The information within this document is based on the Treescene Tree Survey dated 13/10/22 and the Treescene AIA Plan 02/2023.

3. TREES TO BE REMOVED

a. Arboricultural Reasons

Trees T67, T68, T69, T70, T72, T73, G75, T77, T86, G87, T94, T103, G104, T106, G107, G108, T109, T110, T113 and T114 are recommended for removal in the Tree Survey due to poor quality (U category). These are mainly Ash trees infected with Ash Dieback Disease (*Hymenoscyphus fraxineus*).

b. To Facilitate Development

Tree T102 is proposed for removal to accommodate the development layout. This is a C category (low quality) tree as determined in the Treescene Tree Survey dated 13/10/22.

Trees to be removed are indicated on the attached Treescene AIA Plan 02/2023.

4. TREE PRUNING

Some of the trees to be retained contain structural defects/deadwood or may impede vehicle/pedestrian movements within the site. Works to improve tree safety or remove a potential source of nuisance are detailed in the Preliminary Management Recommendations within the Tree Survey. All pruning and felling/coppicing works are to be undertaken by suitably qualified and experienced Arboricultural Contractors working to BS3998:2010 Recommendations for Tree Work.

5. ROOT PROTECTION AREA (RPA) INCURSIONS

There are no conflicts between proposed structures and RPAs of trees to be retained apart from in the following circumstances;

G71- vehicle access track on northern edge of RPA,

T96- surfaced footpath within southern and eastern sections of RPA (the proposed path covers 14.7% of the RPA, less than the 20% permitted in Section 7 of BS5837:2012)

G111- manhole connection on northern fringe of RPA,

T112- manhole connection on northern fringe of RPA.

In all circumstances the incursions are relatively slight and therefore there will be minimal adverse impact upon the future health of the affected trees. However, in order to ensure that the affected trees are not damaged as a result of the development special excavation and construction techniques, to be detailed in a site specific Arboricultural Method Statement (AMS), will be employed in these areas.

6. PROTECTION OF RETAINED TREES

All trees to be retained should be protected by fencing in accordance with the details in BS5837:2012. The implementation of the tree protection on site should be in compliance with a site specific Tree Protection Plan (TPP) and Arboricultural Method Statement (AMS).

7. **IMPACT ON LOCAL AMENITY**

Tree loss in relation to the development focuses only on the clearance of poor quality trees on the boundaries of the site for the reasons of public safety; these trees (mainly Ash infected with Ash Dieback Disease) would require removal on safety grounds in any case irrespective of any development proposals. The existing robust tree belts on all boundaries of the site are retained thus minimising any wider landscape impacts.

Extensive new tree planting within the site is proposed thus mitigating any tree loss and contributing to an enhancement of the local tree stock as a result of the proposed development.



**Arboricultural Method Statement
and
Tree Protection Plan
for
Pontyfelin Lane,
New Inn,
Pontypool**

*Inspected by:-
Julian Wilkes BSc.For, MSc.Land Man, MIC.For, TechArb
Treescene Ltd
The Walled Garden
Old Coedarhydyglyn
St Nicholas
Cardiff
CF5 6SG
Tel No. 029 20599300*

20th February, 2023

**Registered Office: Treescene Limited
The Walled Garden, Old Coedarhydyglyn, St. Nicholas, Cardiff CF5 6SG
Tel. 029 205 99300 Email. trees@treescene.co.uk**

1. **BRIEF**

I have been instructed by Mr. Owain Morgan of Arup to prepare an Arboricultural Method Statement (AMS) and a Tree Protection Plan (TPP) in relation to a proposed development at Pontyfelin Lane, New Inn, Pontypool.

2. **TREE SURVEY**

The information in the AMS and TPP relates to the Treescene Tree Survey dated 13/10/22.

3. **TREES TO BE REMOVED**

Trees to be removed are indicated in the Treescene Arboricultural Impact Assessment (AIA) 20/02/2023.

4. **TREE PRUNING**

Any proposed tree pruning works are those indicated in the Preliminary Tree Management Recommendations in the Treescene Tree Survey dated 13/10/22.

All pruning works are to be undertaken by suitably qualified and experienced Arboricultural Contractors working to BS3998:2010 Recommendations for Tree Work.

5. **TREE PROTECTION PLAN**

The position of the protective barriers is indicated on the enclosed Treescene TPP 02/2023. The tree protection will be installed immediately after the conclusion of the tree works and before the commencement of any construction activity on site.

6. **TREE PROTECTION BARRIERS**

Protective barriers in accordance with BS5837:2012 and the enclosed drawing (Figure 2) will be installed in the locations indicated on the TPP under the supervision of the Arboricultural Consultant. The protective barriers will remain in situ until the completion of the construction work and final site landscaping.

No materials that are likely to have an adverse effect on tree health, such as oil, cement and bitumen will be stored or discharged within the protective barriers. No fires will be lit within 15m of the crown spread of retained trees and concrete will not be mixed or transported within 10m of the trunk of any tree.

7. **EXCAVATION WITHIN THE RPAs**

The AIA indicates that some excavation will be required on the edges of the RPAs of trees G111 and T112 in order to connect drainage into a manhole. In these instances the following method of working will be implemented:

- a) All excavations on the development line will be undertaken by hand with spades, forks or an "Air Spade" (compressed air) taking care not to damage the bark and wood of roots to be retained.
- b) All exposed roots should be cleanly cut with a sharp saw on the line of development.
- c) Any temporarily exposed roots must be protected from direct sunlight, drying out and extremes of temperature by appropriate dampened covering.
- d) All personnel and machinery must remain within the confines of the proposed construction area and not encroach on any unprotected RPA.

The root pruning works are to be undertaken by a suitably qualified and experienced Arboricultural Contractor in strict compliance with BS3998 (British Standards for Tree Work 2010).

8. NO-DIG CONSTRUCTION

The Arboricultural Impact Assessment (AIA) indicates that the installation of a vehicle access track and footpath may conflict with the RPAs of trees G71 and T96. In these circumstances “no-dig” construction techniques will be employed to install the access track and footpath.

The basis of “no-dig” construction is formed by the utilisation of a 3 dimensional geotextile grid e.g. “Geocell”, “Cellweb” or similar products.

Depending on the ground levels in the specific area concerned some loose application of a granular, permeable fill e.g. crushed stone or sharp sand may be required to form finished surface levels.

Once the base level has been achieved the membrane and geotextile grid will be installed and filled with large diameter clean stone in accordance with the manufacturer’s recommendation. The finished surface e.g. permeable tarmac or block pavements will then be laid on top of the 3 dimensional grid.

The geotextile grid will be retained at its edges by the use of pre-formed metal edging secured by metal pins, or similar. A cross-section of no dig construction is attached in Diagram 1.

9. MONITORING AND SUPERVISION

The Arboricultural Consultant will undertake site inspections and monitoring/supervision at the following times:

- a. Pre-commencement meeting with tree contractor to agree tree removal and pruning.
- b. Supervision of installation of protective fencing.
- c. Monitor condition of fencing every 4 weeks during construction.
- d. Supervision of hand excavation/root pruning in relation to excavations within RPAs.
- e. Supervision of “no-dig” construction of footpath/access track.
- f. Supervision of removal of fencing following completion of project.
- g. Monitor condition of retained trees every 6 months following completion of construction for a period of two years.

Figure 2 Default specification for protective barrier

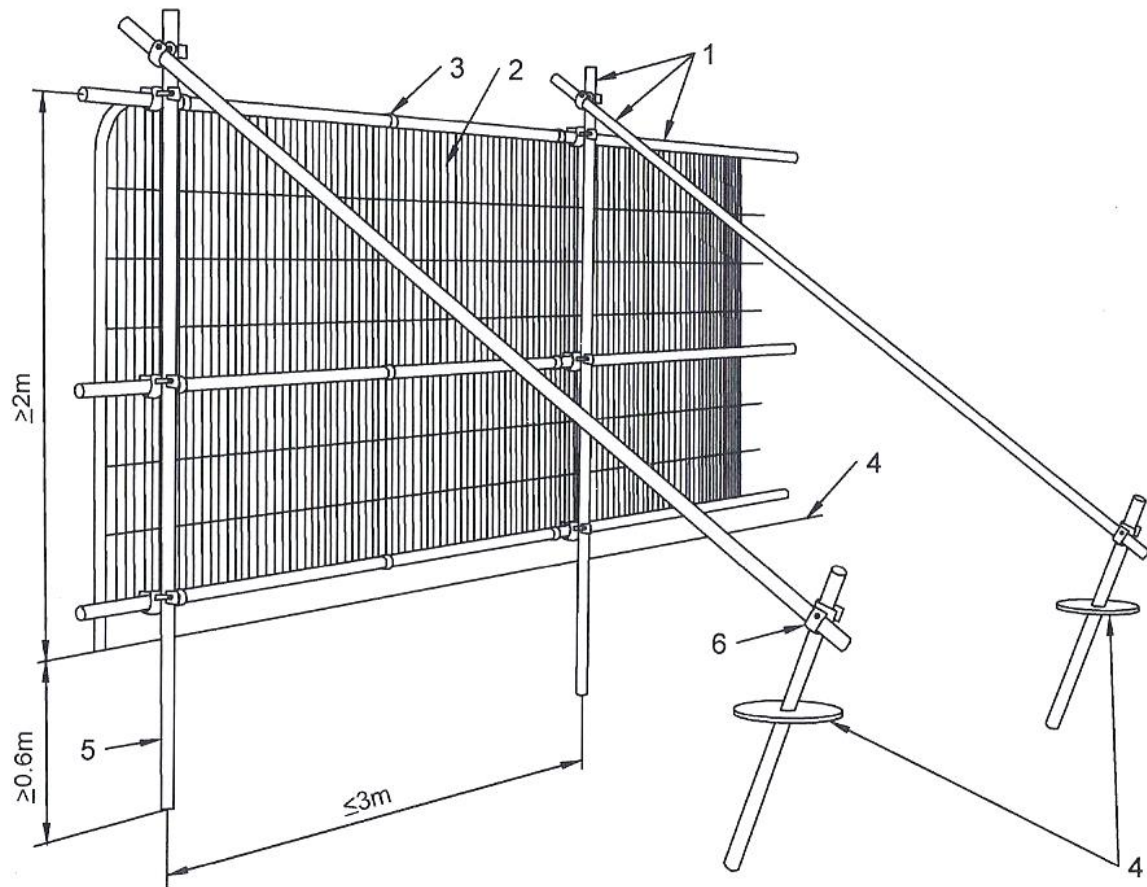

Key

- 1 Standard scaffold poles
- 2 Heavy gauge 2m tall galvanized tube and welded mesh infill panels
- 3 Panels secured to uprights and cross-members with wire ties
- 4 Ground level
- 5 Uprights driven into the ground until secure (minimum depth 0.6m)
- 6 Standard scaffold clamps

Diagram 1. No dig construction method

